



PRODUCT OVERVIEW

The Marvell® Libertas™ 88W8010 and 88W8310 chipset comprises the world's first true, 2-chip 802.11g(b) CMOS client solution. The 88W8010 is an optimized RF-baseband transceiver that integrates a near 20 dBm power amplifier (23 dBm for 802.11b CCK signals), low noise amplifier, voltage-controlled oscillator, frequency synthesizer, as well as other necessary RF and analog functions onto one chip. The 88W8310 product is a single chip that combines the functions of the Direct Sequence Spread Spectrum (DSSS) and Orthogonal Frequency Division Multiplexing (OFDM) baseband processor, Medium Access Control (MAC) processor, on-chip CPU, on-chip memory, advanced security engine, and various host interfaces. The high level of integration, close interaction of RF and digital functions, and a full implementation of the power of management functions specified in IEEE 802.11 minimize the system power requirements. Together, the 88W8010 and 88W8310 chipset supports IEEE 802.11g data rates of 6, 9, 12, 18, 24, 36, 48, and 54 Mbps as well as 802.11b rates of 1, 2, 5.5, and 11 Mbps. There is also support for proprietary data rates of 22 Mbps and 72 Mbps for client applications.

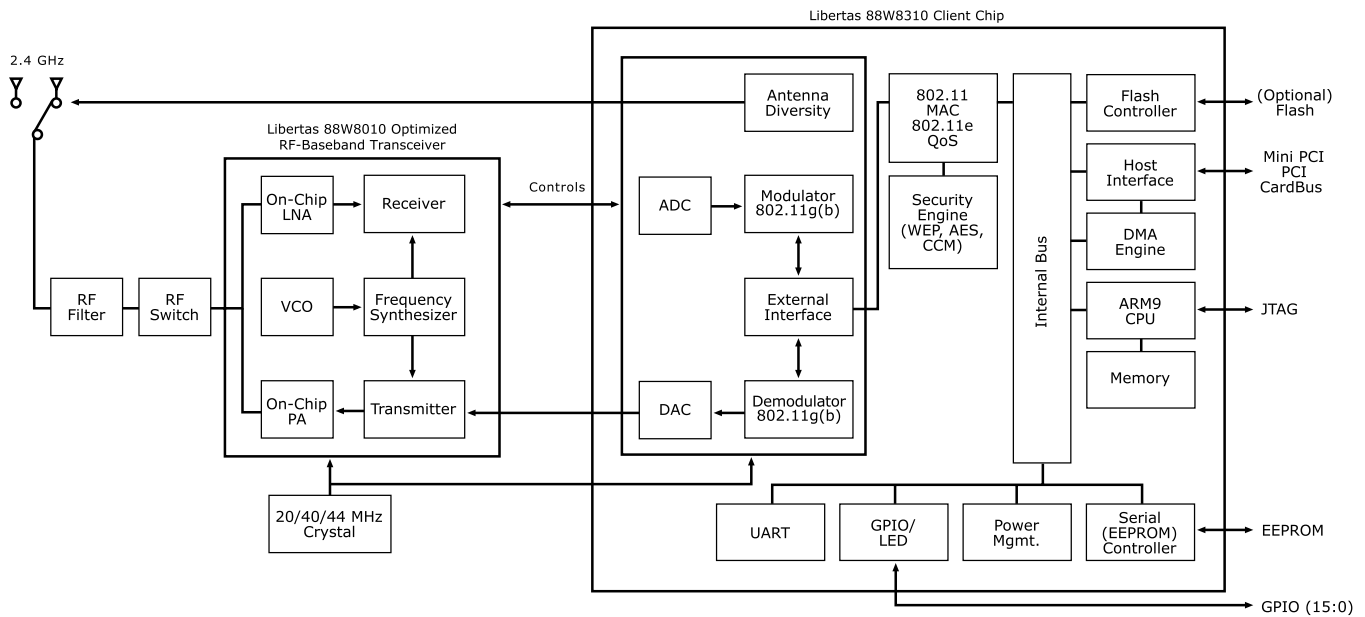

Fig 1. Libertas WLAN 802.11g(b) Client Chipset (88W8010 and 88W8310) Block Diagram

88W8010 FEATURES

- 2.4 GHz ISM Band radio
- Integration of all RF to analog baseband transmit and receive functionalities
- High-performance heterodyne radio architecture
- Highly linear, on-chip power amplifier with 23 dBm and 20 dBm output power at the antenna connector for 802.11b and 802.11g modulation schemes, respectively
- Integrated transmit power loop control for true power detection
- High receiver sensitivity

BENEFITS

- One single chip that is optimized to support all RF to analog baseband functions of the IEEE 802.11g(b) standard
- Reduces BOM cost, simplifies board layout and provides smaller form factor
- Eliminates the need for SAW filter and reduces cost while providing superior performance compared to direct conversion architecture
- Reduces cost, increases range and provides high performance in terms of its ability to output 0 dBm to 20 dBm power at the antenna connector with 0.5 dBm resolution
- Stabilizes power amplifier output at user designated values across temperature, voltage supply and semiconductor variations
- Improves detection of weak signals and increases range





88W8010 FEATURES

- Low power design and advanced power management modes
- Small 7mm x 7mm, 48-pin QFN package

88W8310 FEATURES

- Embedded ARM processor for flexible MAC architecture
- High Multi-Path delay spread tolerance
- Within-packet antenna diversity
- Custom DSP design
- Hardware security engine for WEP and 802.11i AES encryption and CCM message authentication
- Support for 802.11e Quality of Service (QoS)
- On-chip SRAM memory
- Host interfaces include: PCI, Mini PCI and 32-bit Cardbus
- 17mm x 17mm, 256-pin TFBGA package

BENEFITS

- Provides industry-leading low power consumption for transmit, receive, stand-by, and power save operation modes
- Reduced footprint allowing for very compact designs

BENEFITS

- Ensures Libertas 802.11g(b) solution to be forward compatible to the IEEE 802.11g standard
- Longer range and better link robustness (reduces drop-outs)
- Longer range and better transmit and receive performance characteristic
- Superior performance and integration of complex functions in a low power design
- Allows the most secure wireless connections without degradation to wireless throughput performance
- Ensures reliable and simultaneous transmissions of data, voice and video at the same time
- Reduces BOM cost and reduces power consumption
- One chip supports all major clients interfaces
- Pin compatible to the Marvell Libertas 802.11b client chip. Allows easy transition from the Libertas 802.11b to 802.11g(b) products.

APPLICATIONS

The Marvell Libertas 88W8010 and 88W8310 chipset supports the following client adapter cards: CardBus (32-bit), Mini PCI and PCI adapter cards.

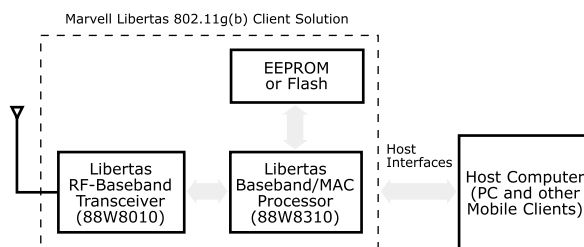

Fig 2. Libertas WLAN 802.11g(b) Client Chipset (88W8010 and 88W8310) Applications Diagram

THE MARVELL ADVANTAGE: The Libertas 802.11g(b) Wireless LAN client chipset also comes with complete reference designs which include such items as board layout designs, firmware, software, manufacturing diagnostic tools, documentation, and other items to assist customers with product evaluation and production. Marvell's worldwide field applications engineers collaborate closely with end customers to develop and deliver new competitive products to market on time. Marvell utilizes recognized world-leading semiconductor foundry and packaging services to reliably deliver high-volume and low cost total solutions.

For more information, visit our website at www.marvell.com.



Marvell Semiconductor, Inc.
 700 First Avenue
 Sunnyvale, CA 94089
 Phone 408.222.2500
www.marvell.com

Copyright © 2003. Marvell. All rights reserved. Marvell, the Marvell logo, Moving Forward Faster, Alaska, and GalNet are registered trademarks of Marvell. Discovery, Fastwriter, GalTis, Horizon, Libertas, Link Street, NetGX, PHY Advantage, Pretera, Raise The Technology Bar, UniMAC, Virtual Cable Tester, and Yukon are trademarks of Marvell. All other trademarks are the property of their respective owners.